

ICC-ES Evaluation Report

ESR-3141

Reissued November 2023

This report also contains:

- CBC Supplement

Subject to renewal November 2024

ICC-ES Evaluation Reports are not to be construed as representing aesthetics or any other attributes not specifically addressed, nor are they to be construed as an endorsement of the subject of the report or a recommendation for its use. There is no warranty by ICC Evaluation Service, LLC, express or implied, as to any finding or other matter in this report, or as to any product covered by the report.

Copyright © 2023 ICC Evaluation Service, LLC. All rights reserved.

<p>DIVISION: 03 00 00— CONCRETE</p> <p>Section: 03 21 00— Reinforcement Bars</p>	<p>REPORT HOLDER: SPLICE SLEEVE JAPAN, LTD.</p>	<p>EVALUATION SUBJECT: NMB SPLICE SLEEVE® UX (SA), NMB SLIM- SLEEVE™ AND NMB SPLICE SLEEVE® UX (SA) SD590 SYSTEMS FOR CONNECTING STEEL REINFORCING BARS</p>	
--	--	--	---

1.0 EVALUATION SCOPE

1.1 Compliance with the following codes:

- 2021, 2018, 2015, 2012 and 2009 [International Building Code® \(IBC\)](#)
- 2013 *Abu Dhabi International Building Code (ADIBC)*†

†The ADIBC is based on the 2009 IBC. 2009 IBC code sections referenced in this report are the same sections in the ADIBC.

1.2 Property evaluated:

- Structural

2.0 USES

The Splice Sleeve Japan, Ltd. (SSJL) NMB Splice Sleeve® UX (SA), NMB Slim-Sleeve™ and NMB Splice Sleeve® UX (SA) SD590 systems are used as mechanical splices of deformed steel reinforcing bars in reinforced concrete construction. The NMB Splice Sleeve UX (SA), NMB Slim-Sleeve and NMB Splice Sleeve UX (SA) SD590 systems comply with Section 25.5.7.1 of ACI 318-19 under the 2021 IBC and ACI 318-14 under the 2018 and 2015 IBC (Section 12.14.3.2 of ACI 318-11 and -08 for the 2012 and 2009 IBC) (ACI 318 as referenced in Section 1901.2 of the IBC) for use as tension and compression mechanical connections of deformed steel reinforcing bars.

The NMB Splice Sleeve UX (SA) and NMB Slim-Sleeve connectors are used with SS Mortar® to splice ASTM A615 Grade 60, or ASTM A706 Grade 60, deformed bars, forming NMB Splice Sleeve UX (SA) and NMB Slim-Sleeve systems, respectively. The NMB Splice Sleeve UX (SA) and NMB Slim-Sleeve systems comply with the Type 1 and Type 2 mechanical splice requirements of Section 18.2.7.1 of ACI 318-19 under the 2021 IBC and ACI 318-14 under the 2018 and 2015 IBC (Section 21.1.6.1 of ACI 318-11 and -08 for the 2012 and 2009 IBC), and are for use where Type 1 or Type 2 mechanical splices are specified by the IBC and ACI 318.

The NMB Splice Sleeve 9UX (SA) SD590 connector is used with SS Mortar 120N™ to splice No. 9 Grade 80 deformed steel reinforcing bars complying with ASTM A615-09b or ASTM A706-09b, forming the NMB Splice Sleeve 9UX (SA) SD590 system, which complies with Section 18.2.7.1 of ACI 318-19 under the 2021 IBC and ACI 318-14 under the 2018 and 2015 IBC (Section 21.1.6.1 of ACI 318-11 and -08 for the 2012 and 2009 IBC) for Type 1 and Type 2 splices.

Exception: The use of the NMB Splice Sleeve 9UX (SA) SD590 in special seismic systems under the 2018 IBC and earlier is outside the scope of this evaluation report since Section 20.2.2.4 of ACI 318-14 (Section 21.1.5.2 of ACI 318-11 and -08 for the 2012 and 2009 IBC) specifies a maximum yield strength used for design calculations of 60,000 psi (maximum steel grade of 60 ksi for the 2012 and 2009 IBC).

Under the 2021 IBC, the Splice Sleeve Japan, Ltd. (SSJL) NMB Splice Sleeve® UX (SA), NMB Slim-Sleeve™ and NMB Splice Sleeve® 9UX (SA) SD590 systems may be used as Type 2HS splices, which are Type 2 splices intended for use with reinforcing bars conforming to ACI 318-19 Section 20.2.1.3(b).

3.0 DESCRIPTION

3.1 NMB Splice Sleeve® UX (SA) Connectors:

The Type UX (SA) NMB Splice-Sleeve connectors consist of straight and half-tapered steel cylinders. A Type UX (SA) NMB Splice-Sleeve has a narrow end and a wide end, and is used to splice two, equal-diameter, deformed steel reinforcing bars. The midsection of the interior of the sleeve is provided with a rebar stop that establishes the proper embedment of the reinforcing bars. The sleeves are iron castings manufactured in accordance with JIS G5502, Grade FCD700-2 [minimum yield and tensile strengths of 60,900 and 101,500 psi (420 and 700 MPa), respectively] for all sleeve sizes except 5UX (SA), and Grade FCD450-10 [minimum yield and tensile strengths of 40,600 and 65,200 psi (280 and 450 MPa), respectively] for the 5UX (SA) sleeve. The NMB Splice-Sleeve UX (SA) connector configuration and dimensions, and the required rebar embedment lengths, are provided in [Figure 1](#) and [Tables 1](#) and [2](#).

3.2 NMB Slim-Sleeve™ Connectors:

The NMB Slim-Sleeve connectors are similar in shape and dimensions to the NMB Splice-Sleeve UX (SA) connectors except that the two ends of the NMB Slim-Sleeve are symmetrical and NMB Slim-Sleeve connectors are used to splice two equal-diameter, deformed reinforcing bars. The sleeves are iron castings manufactured in accordance with JIS G5502, Grade FCD700-2 [minimum yield and tensile strengths of 60,900 and 101,500 psi (420 and 700 MPa), respectively] for all sleeve sizes. The NMB Slim-Sleeve connector configuration and dimensions, and the required rebar embedment lengths, are provided in [Figure 2](#) and [Tables 3](#) and [4](#).

3.3 NMB Splice Sleeve® 9UX (SA) SD590 Connector:

NMB Splice Sleeve 9UX (SA) SD590 Connector is produced with the same shape and dimensions, and using the same manufacturing process, as for the NMB Splice Sleeve 9UX (SA) Connector, except the sleeve is an iron casting manufactured in accordance with JIS G5502, Grade FCD800-2 [minimum yield and tensile strengths of 85,600 and 116,000 psi (590 and 800 MPa), respectively], and is used to splice two No. 9, Grade 80, deformed steel reinforcing bars. The NMB Splice-Sleeve 9UX (SA) SD590 connector configuration and dimensions, and the required rebar embedment lengths, are provided in [Figure 1](#) and [Tables 1](#) and [2](#).

3.4 SS Mortar® and SS Mortar 120N™:

SS Mortar and SS Mortar 120N are non-shrink, high-early-strength, pre-dry-mixed, cement grouts manufactured by Splice Sleeve Japan, Ltd., in Itoigawa-shi, Niigata, Japan. The mortar is packaged in 33-pound (15 kg) and 55-pound (25 kg) moisture-resistant bags for SS Mortar, and 55-pound (25 kg) moisture-resistant bags for SS Mortar 120N. The SS Mortar is to be used with the NMB Splice Sleeve UX (SA) and NMB Slim-Sleeve connectors. The SS Mortar 120N is to be used with the NMB Splice Sleeve 9UX (SA) SD590 connector. The material has a shelf life of 12 months when stored in a cool, dry environment.

3.5 Reinforcing Steel Bars:

The reinforcing steel bars must be uncoated deformed bars complying with ASTM A615 Grade 60 or ASTM A706 Grade 60, for use with the NMB Splice Sleeve UX (SA) and NMB Slim-Sleeve connectors, and must be No. 9, ASTM A615 Grade 80 or ASTM A706 Grade 80, uncoated deformed bars for use with the NMB Splice Sleeve 9UX (SA) SD590 connector.

4.0 DESIGN AND INSTALLATION

4.1 General:

The NMB Splice Sleeve UX (SA), NMB Slim-Sleeve and NMB Splice Sleeve UX (SA) SD590 systems must be designed and installed in accordance with the IBC and this evaluation report. The splice locations must be detailed on plans approved by the code official. All required spacing and concrete protection (cover) described

in IBC Table 721.1(1) (Table 720.1(1) for the 2009 IBC) and applicable sections of ACI 318 must be measured from the outside of the splice systems.

4.2 Installation:

4.2.1 NMB Splice Sleeve® UX (SA) and 9UX (SA) SD590 Systems:

4.2.1.1 Preparation and Installation: All reinforcement must be clean and free from loose rust, oils, dust and other foreign material. All foreign matter and water must be removed from the sleeves.

The sleeves must be prepared and installed in accordance with the applicable code, the approved construction documents, and the recommendations noted in the “NMB Splice Sleeve System User’s Manual for UX(SA), 18U and NXII Sleeve” for model UX(SA), and the “User’s Manual for NMB Splice Sleeve UX(SA) SD590” for model UX(SA) SD590.

Sleeves must be prepared by installations of elastomer plug (EP), PVC grout tubes and pipe seals (PS) in accordance with the manufacturer’s installation instructions.

The prepared sleeve must be installed on the first rebar so that the bar end is in contact with the rebar stop inside the sleeve, to assure the specified embedment length. The minimum embedment length of connected bars must be as shown in [Tables 1](#) and [2](#).

4.2.1.2 Grouting: Sleeves must be grouted with SS Mortar [for model UX (SA)] or SS Mortar 120N [for model UX (SA) SD590], which are mixed with clean water according to the grout manufacturer’s recommendations. Grout must be proportioned so that the stable splice strength can be attained by achieving a minimum strength of not less than 13,000 psi (89.6 MPa) for SS Mortar or 15,500 psi (106.9MPa) for SS Mortar 120N in 28 days, as determined by testing specimens made according to ASTM C109 and recommendations of Splice Sleeve Japan, Ltd. Grout must be pumped into the sleeves from the inlet grout tube until it flows freely from the outlet tube. Immediately after grout outflow is observed, and before the pump nozzle is removed, a rubber stopper must be inserted into the outlet grout tube. Immediately upon removal of the nozzle from the inlet grout tube, a rubber stopper must be inserted into the inlet grout tube in such a manner as to prevent leakage of grout from the sleeve. All spaces within the sleeve must be fully penetrated with the approved grout, and excess grout must be removed.

4.2.2 NMB Slim-Sleeve™ Systems:

4.2.2.1 General: The NMB Slim-Sleeve system must be prepared and installed in accordance with the applicable code, the approved construction documents, and the recommendations noted in the “NMB Splice Sleeve System User’s Manual for NMB Slim-Sleeve.”

4.2.2.2 Preparation: All reinforcements must be clean and free from loose rust, oils, dust and other foreign material. All foreign matter and water must be removed from the sleeve.

4.2.2.3 Installations for Vertical (Columns) and Horizontal (Beam) Applications: Refer to manufacturer’s installation instructions for detailed requirements, including, but not limited to, required accessories, installation sequences, means to ensure that the minimum embedment lengths of reinforcing bars are achieved, and required visual inspections prior to grouting SS Mortar.

4.2.2.4 Grouting: The NMB Slim-Sleeve must be grouted with SS Mortar, which is mixed with clean water according to the grout manufacturer’s recommendations. Grout must be proportioned so that the stable splice strength can be attained by achieving a minimum strength of not less than 13,000 psi (89.6MPa) in 28 days, as determined by testing specimens made according to ASTM C109 and recommendations of Splice Sleeve Japan, Ltd. Grout must be poured or pumped into the sleeves with an appropriate hand-operated pump or handy injector as recommended by the sleeve manufacturer, depending upon the location of the sleeves. For both vertical and horizontal applications, grout must be pumped into the slim valve (inlet port) until it flows freely from the outlet port. All spaces within the sleeve must be fully penetrated with the approved grout, and excess grout must be removed.

4.2.3 Grout Testing:

Measurement of consistency of the grout is necessary in order to determine and maintain the proper amount of mixing water to assure a smooth, pumpable grout matrix. Consistency flow tests must be run by using a flow table to test the flow of batches of grout mixture in accordance with the Japanese Architectural Standard Specification (JASS) standard 15 M103, entitled “Tests for quality evaluation of self-leveling materials.” The grout must flow to a diameter of 6 inches to 9¹/₄ inches (152 to 235 mm) for SS Mortar, and a diameter of 7.28 inches to 11.22 inches (185 to 285 mm) for SS Mortar 120N. Grout strength must be determined by

testing of 2-inch (51 mm) cube specimens in accordance with ASTM C109 and ASTM C942, and the recommendations of Splice Sleeve Japan, Ltd. The grout cubes must be kept in a curing box for 24 hours. During the following day, the grout cubes must be stripped from the curing box and be submerged in a container with water, which must be kept under the same condition as the jobsite until the compressive strength testing.

4.3 Special Inspection:

Special inspection is required in accordance with IBC Section 1705 (Section 1704 of the 2009 IBC). In addition to verifying installation of steel reinforcing bar splices in accordance with this report, the special inspector must verify the grade and size of reinforcing bars; reinforcing bar embedment; coupler identification; grout identification; field preparation of components; grout mixing, grouting, curing and testing; and assembly of the components resulting in spliced bars.

5.0 CONDITIONS OF USE:

The NMB Splice Sleeve® UX (SA), NMB Slim-Sleeve™ and NMB Splice Sleeve® UX (SA) SD590 systems described in this report comply with, or are suitable alternatives to what is specified in, those codes listed in Section 1.0 of this report, subject to the following conditions:

- 5.1 The splices must be identified and installed in accordance with the applicable code, the manufacturer's instructions and this report. In the event of conflict between this report and the manufacturer's instructions, this report governs.
- 5.2 Special inspection must be provided in accordance with Section 4.3 of this report.
- 5.3 The minimum concrete cover must be in accordance with the IBC and must be measured from the outer surface of the coupler.
- 5.4 Splice locations must comply with applicable IBC requirements and be noted on plans approved by the code official.
- 5.5 Under the 2021, 2018 and 2015 IBC, for structures regulated by Chapter 18 of ACI 318-19 and ACI 318-14 (as required by 2021, 2018 and 2015 IBC Section 1905.1, as applicable), to splice uncoated, deformed longitudinal reinforcing bars resisting earthquake-induced flexure, axial force, or both, in special moment frames, special structural walls, and all components of special structural walls including coupling beams and wall piers, with the NMB Splice Sleeve systems, mill certificates of reinforcing bars must be submitted to the code official as evidence that the steel reinforcing bars comply with ACI 318-19 and ACI 318-14 Section 20.2.2.5.
- 5.6 Under the 2012 IBC, for structures regulated by Chapter 21 of ACI 318-11 (as required by 2012 IBC Section 1905.1), to splice uncoated, deformed longitudinal reinforcing bars resisting earthquake-induced flexure, axial force, or both, in special moment frames, special structural walls, and all components of special structural walls including coupling beams and wall piers, with the NMB Splice Sleeve systems, mill certificates of reinforcing bars must be submitted to the code official as evidence that the steel reinforcing bars comply with ACI 318-11 Section 21.1.5.2.
- 5.7 Under the 2009 IBC, for structures regulated by Chapter 21 of ACI 318-08 (as required by 2009 IBC Section 1908.1), to splice uncoated, deformed longitudinal reinforcing bars resisting earthquake-induced flexural and axial forces in frame members, structural walls and coupling beams, with the NMB Splice Sleeve systems, mill certificates of reinforcing bars must be submitted to the code official as evidence that the steel reinforcing bars comply with ACI 318-08 Section 21.1.5.2.
- 5.8 The NMB Splice Sleeve UX (SA) and NMB Slim-Sleeve connectors must be used with SS Mortar, and the NMB Splice Sleeve UX (SA) SD590 connector must be used with SS Mortar 120N, which must be manufactured by Splice Sleeve Japan, Ltd., in accordance with the approved quality documentation.
- 5.9 The use of NMB Splice Sleeve UX (SA) SD590 connector and the SS Mortar 120N mechanical splice system to splice Grade 80 bars under Section 18.2.7 ACI 318-14 (Section 21.1.6 of ACI 318-11 and -08 for the 2012 and 2009 IBC) is outside of the scope of this evaluation report.
- 5.10 The use of NMB Splice Sleeve UX (SA), NMB Slim-Sleeve and NMB Splice Sleeve UX (SA) SD590 systems in fire-resistance-rated construction, is outside the scope of this evaluation report.
- 5.11 The evaluation of corrosion resistance of the mechanical splice is outside the scope of this evaluation and shall be considered by the registered design professional during the design.

5.12 The NMB Splice Sleeve systems are manufactured under a quality control system with inspections by ICC-ES.

6.0 EVIDENCE SUBMITTED

Data in accordance with the [ICC-ES Acceptance Criteria for Mechanical Splice Systems for Steel Reinforcing Bars \(AC133\)](#), dated October 2020 (editorially revised August 2022).

7.0 IDENTIFICATION

- 7.1 The ICC-ES mark of conformity, electronic labeling, or the evaluation report number (ICC-ES ESR-3141) along with the name, registered trademark, or registered logo of the report holder [and/or listee] must be included in the product label. (REMOVE[Electronic labeling is the ICC-ES web address (www.icc-es.org); specific URL related to the report; or the ICC-ES machine-readable code placed on the aforementioned items.]
- 7.2 In addition, the [the [product name(s)] is/are identified [Additional identification and acceptance criteria requirements]
- 7.3 Each NMB Splice Sleeve is marked with the company logo (NMB), the sleeve model and size [such as 9UX for both NMB Splice Sleeve UX (SA) and NMB Splice Sleeve UX (SA) SD590 connectors, and S9U for NMB Slim-Sleeve connector], the lot number, and “T2” indicating a Type 2 or Type 2HS mechanical splice. Each NMB Splice Sleeve UX (SA) SD590 connector is also marked with “SD590.” Each container (canvas bag) of sleeves is identified with a product label which, at a minimum, includes the report holder’s name (Splice Sleeve Japan, Ltd.) and address, the product model and size, and the ICC-ES evaluation report number (ICC ESR-3141). Each bag of SS Mortar and SS Mortar 120N is marked with report holder’s name (Splice Sleeve Japan, Ltd.) and address, the product description (NMB Splice Sleeve System), the ICC-ES evaluation report number (ESR-3141), and mixing instructions. Additionally, a lot number is printed on each bag of SS Mortar and SS Mortar 120N which identifies the production date and manufacturing facility.
- 7.4 The report holder’s contact information is the following:

SPLICE SLEEVE JAPAN, LTD.
17-1 NIHONBASHI HAKOZAKI-CHO
CHUO-KU, TOKYO 103-0015
JAPAN
+81-3-5642-6120
www.splice.co.jp

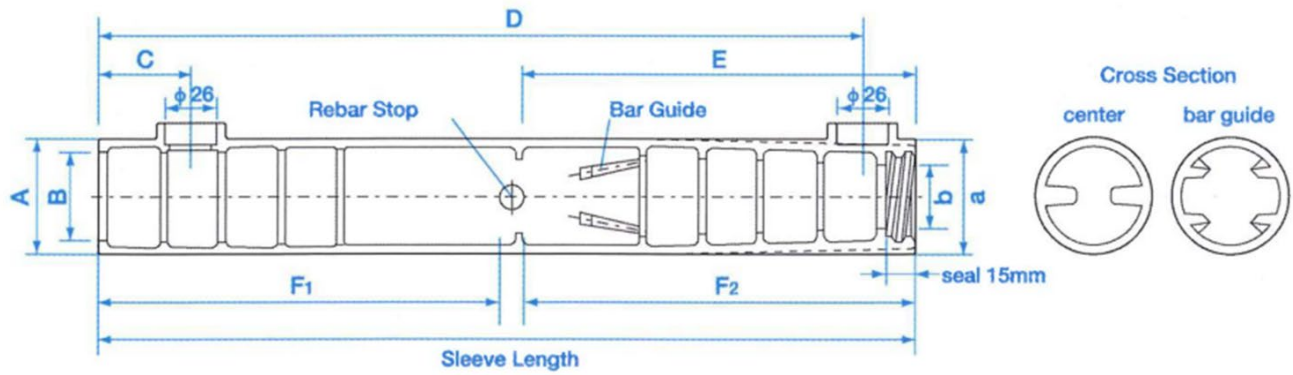

FIGURE 1—NMB SPLICE SLEEVE UX (SA) AND UX (SA) SD590

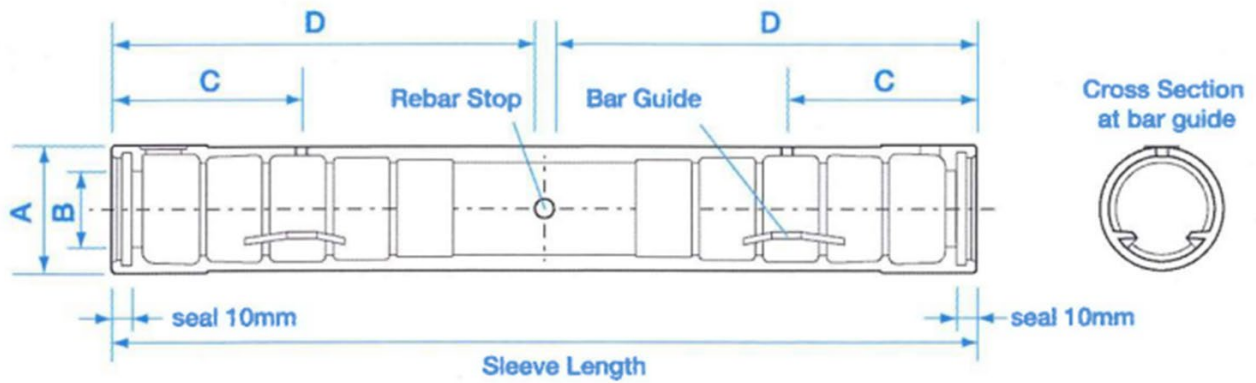

FIGURE 2—NMB SLIM-SLEEVE

TABLE 1—DIMENSIONS OF NMB UX (SA) AND UX (SA) SD590 SLEEVES¹

DIMENSIONS OF NMB UX (SA) SLEEVES											REQUIRED REBAR EMBEDMENT LENGTH			
Sleeve No.	Bar Diameter (in.)	Bar Size		Sleeve Length (in.)	Sleeve Diameter (in.)			Inlet Position (C) (in.)	Outlet Position (D) (in.)	Rebar Stop (E) (in.)	Wide End (F1) (in.)		Narrow End (F2) (in.)	
		ASTM	JIS		O.D. (A,a)	I.D.					Min.	Max.	Min.	Max.
						Wide End (B)	Narrow End (b)							
5UX(SA)	0.625	#5	D16	9.65	1.77	1.26	0.87	1.85	8.58	4.53	3.54	4.72	4.13	4.53
9UX(SA)	1.128	#9	D29	16.34	2.48	1.89	1.38	1.85	15.28	7.87	6.89	8.07	7.48	7.87
10UX(SA)	1.270	#10	D32	17.91	2.60	2.01	1.54	1.85	16.85	8.66	7.68	8.86	8.27	8.66
11UX(SA)	1.410	#11	D36	19.49	2.80	2.17	1.73	1.85	18.43	9.45	8.46	9.65	9.06	9.45
14UX(SA)	1.693	#14	D43	24.41	3.23	2.44	2.01	1.85	23.35	11.81	10.83	12.20	11.42	11.81

For SI: 1 inch = 25.4 mm.

¹9UX (SA) SD590 sleeve has the same dimensions as those of 9UX (SA) sleeve.

TABLE 2—DIMENSIONS OF NMB UX (SA) AND UX (SA) SD590 SLEEVES (Metric Units)¹

DIMENSIONS OF NMB UX (SA) SLEEVES											REQUIRED REBAR EMBEDMENT LENGTH			
Sleeve No.	Bar Diameter (in.)	Bar Size		Sleeve Length (mm)	Sleeve Diameter (mm)			Inlet Position (C) (mm)	Outlet Position (D) (mm)	Rebar Stop (E) (mm)	Wide End (F1) (mm)		Narrow End (F2) (mm)	
		ASTM	JIS		O.D. (A,a)	I.D.					Min.	Max.	Min.	Max.
						Wide End (B)	Narrow End (b)							
5UX(SA)	0.625	#5	D16	245	45	32	22	47	218	115	90	120	105	115
9UX(SA)	1.128	#9	D29	415	63	48	35	47	388	200	175	205	190	200
10UX(SA)	1.270	#10	D32	455	66	51	39	47	428	220	195	225	210	220
11UX(SA)	1.410	#11	D36	495	71	55	44	47	468	240	215	245	230	240
14UX(SA)	1.693	#14	D43	620	82	62	51	47	593	300	275	310	290	300

¹9UX (SA) SD590 sleeve has the same dimensions as those of 9UX (SA) sleeve.

TABLE 3—DIMENSIONS OF NMB SLIM-SLEEVES

DIMENSIONS OF NMB SLIM-SLEEVES										REQUIRED REBAR EMBEDMENT LENGTH (in.)	
Sleeve No.	Bar Diameter (in.)	Bar Size		Sleeve Length (in.)	Sleeve Diameter (in.)		Set Screw Position (C) (in.)	Rebar Stop (D) (in.)	Min	Max	
		ASTM	JIS		O.D. (A)	I.D. (B)					
S9U	1.128	#9	D29	14.57	2.13	1.38	2.95	7.09	6.69	7.28	
S11U	1.410	#11	D36	17.72	2.56	1.69	3.94	8.66	8.27	8.86	

For SI: 1 inch = 25.4 mm.

TABLE 4—DIMENSIONS OF NMB SLIM-SLEEVES (Metric Units)

DIMENSIONS OF NMB SLIM-SLEEVES										REQUIRED REBAR EMBEDMENT LENGTH (mm)	
Sleeve No.	Bar Diameter (in.)	Bar Size		Sleeve Length (mm)	Sleeve Diameter (mm)		Set Screw Position (C) (mm)	Rebar Stop (D) (mm)	Min	Max	
		ASTM	JIS		O.D. (A)	I.D. (B)					
S9U	1.128	#9	D29	370	54	35	75	180	170	185	
S11U	1.410	#11	D36	450	65	43	100	220	210	225	

DIVISION: 03 00 00—CONCRETE
Section: 03 21 00—Reinforcement Bars

REPORT HOLDER:

SPLICE SLEEVE JAPAN, LTD.

EVALUATION SUBJECT:

NMB SPLICE SLEEVE® UX (SA), NMB SLIM-SLEEVE™ AND NMB SPLICE SLEEVE® UX (SA) SD590 SYSTEMS FOR CONNECTING STEEL REINFORCING BARS

1.0 REPORT PURPOSE AND SCOPE**Purpose:**

The purpose of this evaluation report supplement is to indicate that NMB Splice Sleeve® UX (SA), NMB Slim-Sleeve™ and NMB Splice Sleeve® UX (SA) SD590 Systems for Connecting Reinforcing Bars, described in ICC-ES evaluation report ESR-3141, have also been evaluated for compliance with the code noted below.

Applicable code edition:

2022 *California Building Code* (CBC)

For evaluation of applicable chapters adopted by the California Office of Statewide Health Planning and Development (OSHPD) AKA: California Department of Health Care Access and Information (HCAI) and the Division of State Architect (DSA), see Sections 2.1.1 and 2.1.2 below.

2.0 CONCLUSIONS**2.1 CBC:**

The NMB Splice Sleeve® UX (SA), NMB Slim-Sleeve™ and NMB Splice Sleeve® UX (SA) SD590 Systems for Connecting Reinforcing Bars, described in Sections 2.0 through 7.0 of the evaluation report ESR-3141, comply with CBC Chapter 19, provided the design and installation are in accordance with the 2021 *International Building Code*® (IBC) provisions noted in the evaluation report and the additional requirements of CBC Chapters 16, 17 and 19, as applicable.

2.1.1 OSHPD:

The applicable OSHPD Sections and Chapters of the CBC are beyond the scope of this supplement.

2.1.2 DSA:

The applicable DSA Sections and Chapters of the CBC are beyond the scope of this supplement.

This supplement expires concurrently with the evaluation report, reissued November 2023.